



X⁵ - Pack X-ray Inspection System

Designed for Food & Packaging Industries

X-Ray
Detection

Product Highlights

- The X⁵ Pack is designed to integrate into line with a built-in reject station and is available in 300 mm, 500 mm and 600 mm belt width models
- Good detection of all metals, bone, glass and dense plastics, even in foil trays or metalized film
- Belt Speeds of up to 60 m/min with pack speeds of up to 200 p/pmin (Based on a typical Ready Meal size)
- Fast inspection with the Set-up wizard automatically optimising the X⁵ Pack for each product type allowing you to learn and switch within minutes
- Reliable Heavy duty conveyor components, built for 24/7 operation with pass key Protective Set-up for added security and control
- Windows 10 PC with modem, Ethernet and Front Access USB Port



Versatile Detection with AAT Technology

AAT Technology allows 0.4 mm Diode setting for very small metal contaminants, with the option of switching to 0.8 mm & 1.6 mm to find softer contaminants such as Bone, Ceramic and Glass.



Easy to Use Intuitive Full Colour Touchscreen

The X⁵ Pack includes an Icon driven full colour touchscreen control interface including multi-level password access and data logged events for traceability (designed to comply with CFR21 Part 11 requirements)

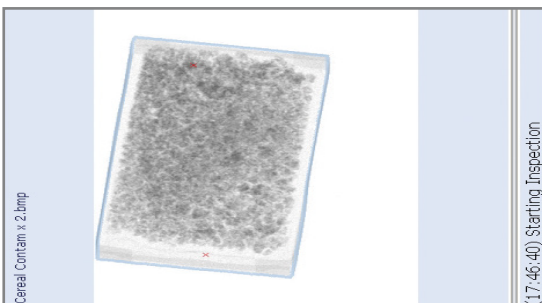

Data Logged Events and Images for Full Traceability

Date stamped reject images designed to comply with CFR21 Part 11 requirements are internally stored and can be removed via USB or Ethernet.

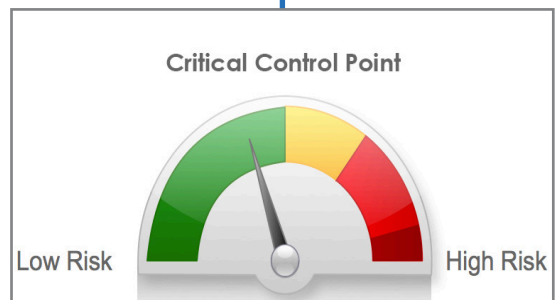

Fully Enclosed CCP Solution with Integrated Reject Station

All in one system with optional retail compliance offers complete control and removes risk.

Technical Specification

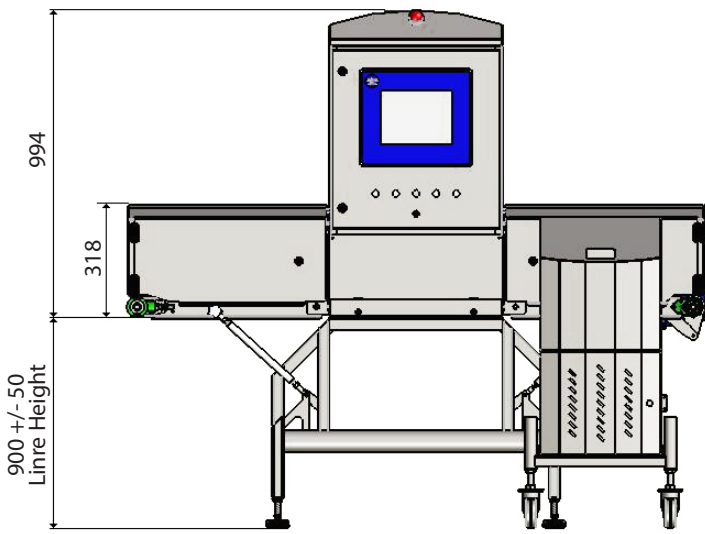
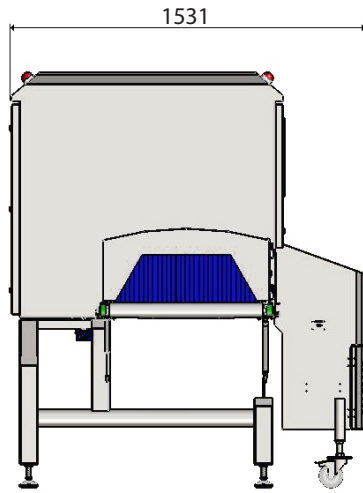

All dimensions in mm

Machine in picture is based on 600 Model

Finish	304 Brushed Stainless Steel
System Length	2000 m
Line Height Option	700 - 1100 mm (+/- 50 mm)
X-Ray Output	210 W (60 kV 3.5 mA) (MKIII)
IP Rating	IP66
Belt Width	300/500/600 mm
Belt Type	PU Blue Belt
Max Product Weight	50 kg
Speed Range	30-60 m/min
Power Requirements	230 V AC, 50 Hz or 110 V AC 60 Hz, Single Phase Mains
Cooling	Vortex or AC Air Conditioning
Operating Environment (Vortex Standard)	2 -10°C with warm up 10 to 25°C Vortex
Operating Environment AC Air Conditioning (Option)	25°C to 35°C AC Air Conditioning (Cabinet reduced to NEMA 4X with AC Option)
X-Ray Safety	Leakage less than 1 µSv/h
Detection Algorithms	15 Multilayers Algorithms combined in any combinations
Reporting	Event, Batch, Shift, PVS
Data Retrieval	Via USB, Ethernet, Enet

Product Inspection Window Sizes

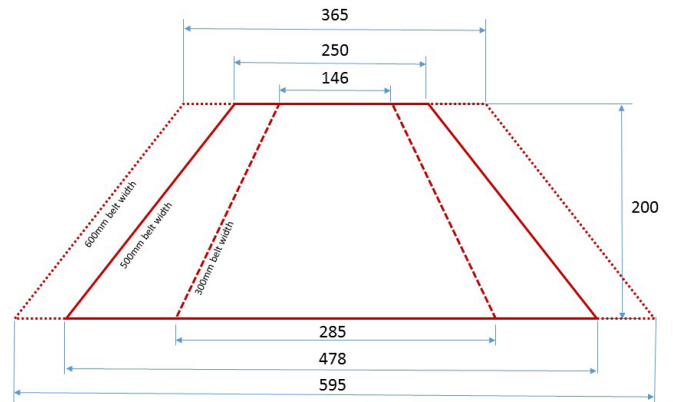

Included Automatic Reject Options

The X³ Pack is supplied as standard with one of the following options:

- Pusher
- Air-blast, single nozzle
- Air-blast, dual nozzle

