



CW3 RUN-WET® Combo System

Designed for Harsh Washdown Environments

The CW3 RUN-WET® Combo System is a fully IP69 rated checkweigher and metal detector system designed to the latest industry leading principles for optimum hygienic standards.

Product Highlights

- A combination system for high-care, harsh washdown environments handling raw ingredients or food processed prior to cooking or final packaging
- Fully IP69 rated to withstand high-pressure, high-temperature cleaning
- Multilevel password protection via RFID tags provides secure access and are logged against events for traceability (CFR21 part11)
- Single touchscreen control via the checkweigher complete with icon driven menus for easy operation and integrated machine communication for safe product transfer
- With this checkweigher and metal detector system, purchasing, installation and support is from one supplier, simplifying the management of this CCP
- Extensive data logging and reporting via USB or ethernet for HACCP and retail compliance



Technical Specification

	Models	
	1500L	6000M
Weight Range (g) MID/R51 Approved	50 - 1500	50 - 6000
Weight Range (g) Non - Approved	10 - 1500	25 - 6000
Belt Width (mm)	200 300	200 300 400
Metal Detector App Height (mm)	100 150 200 250	
Finish	304 Stainless Steel	
Line Height Options (mm)	775 - 825 825 - 925 900 - 1100 1150 - 1550	
System Length (mm) - Application Dependant	Infeed: 800 - 1300 (in 100mm increments) Weighing Platform: 1500M 250 - 500 6000M 300 - 700 (in 50mm increments) Outfeed: 1000 - 1300 (in 100mm increments)	
Maximum Speed	115m/min	
Supply Voltages	110 or 230V/1ph / N+E 50 or 60Hz	
Air Supply	5 to 8 Bar, 72-116 PSI	
Operating Temperatures	0-40°C	
IP Rating	IP69	
Belt Type	PU Anti Static (Steam / Vapour Proof)	
Data Retrieval	Via USB, Ethernet, TRACS	
Automatic Reject Options	Pusher, Dual Air Blast	

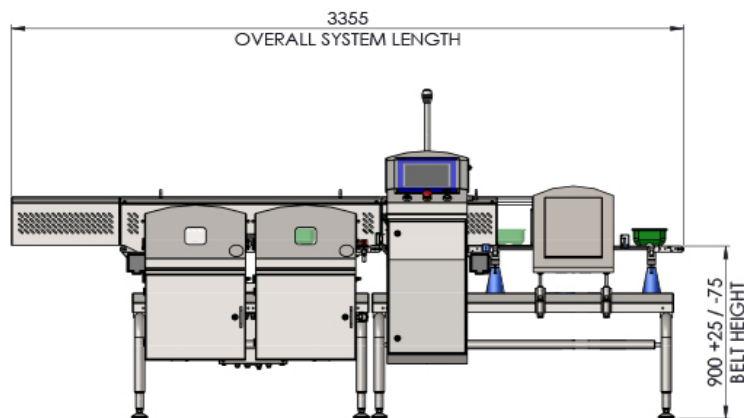
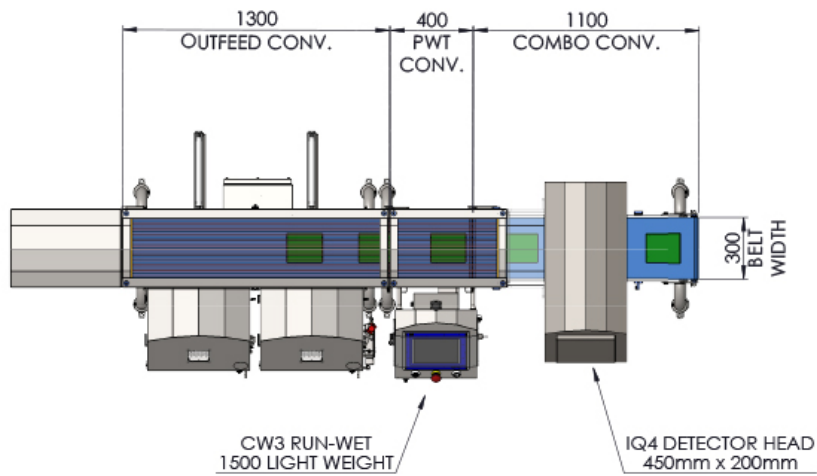

Direction of Flow - Right to Left