

WA 14-10 SLIM

MULTIHEAD WEIGHER



MAIN FEATURES

- 1 High Flexibility
- 2 User-friendly HMI
- 3 Quick-release components
- 4 Wash-down execution

BENEFITS

- 1 High-speed - Low product drop - Gentle product handling
- 2 Easy interface with quick access to trouble-shooting tools for increased OEE
- 3 Easy sanitation and quick maintenance
- 4 Hygienic design components

Compact-design Multi-Head weigher especially conceived for small weighments, high speed applications with gentle product handling. Easy detachable product contact parts available in plain execution, embossed or special coatings, weighing or counting mode. Ideal for Confectionery, Snacks, Dry fruits and many other markets.

TECHNICAL DATA

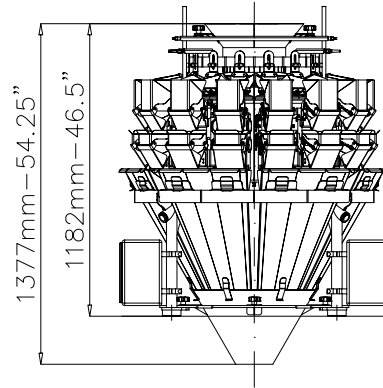
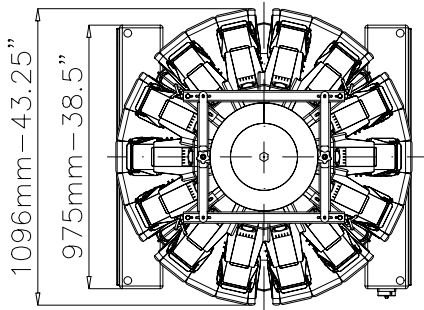

Max. speed	120 wpm
Weigh heads	14
Bucket volume	1,0l
Max. discharge volume (single dump)	2,5l
Discharge weight range (single dump)	10 g - 750 g
Max. piece length	85 mm
Product distribution	Vibratory or rotary distribution cone with loadcell to control product infeed
Product contact parts	Stainless steel AISI 304 Embossed plate* and special coatings*
Drive	Springless, high speed stepper motors
Loadcells	C3 accuracy class, OIML approved R76 class
Electronic platform	Industrial PC
HMI	12" (18"*) colour touch screen with remote control capability (augmented reality feature*)
Program memory	over 1000 recipes
Power supply (opt. excluded)	230 Vac±5%, 1 ph, neutral, GND, 50/60 Hz, 1.2 kW, 6 A (3 A @ 480 V)
Compressed air (opt. excluded)	180 l/min @ 7 bar
Machine dimensions (W x D x H)	975 x 975 x 1377 mm (38.5 x 38.5 x 54.25")
Machine weight	425 kg

* optional