

WA 14-50

MULTIHEAD WEIGHER



MAIN FEATURES

- 1 High Flexibility
- 2 User-friendly HMI
- 3 Quick-release components
- 4 Wash-down execution

BENEFITS

- 1 Can handle a wide range of products and applications
- 2 Easy interface with quick access to trouble-shooting tools for increased OEE
- 3 Easy sanitation and quick maintenance
- 4 Hygienic design components

High-accuracy Multi-Head weigher conceived for medium-large volume weighments, suitable for dry, fresh and frozen food. Easy detachable product contact parts available in plain execution, embossed or special coatings, weighing or counting mode. Ideal for Meat, Cheese, Petfood, Produce and many other markets.

TECHNICAL DATA

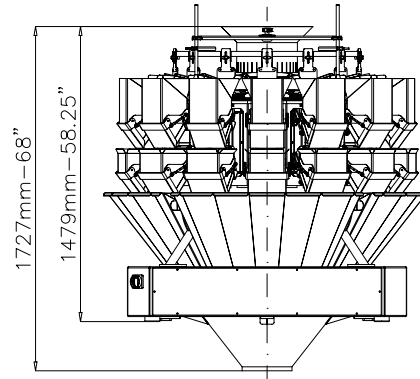
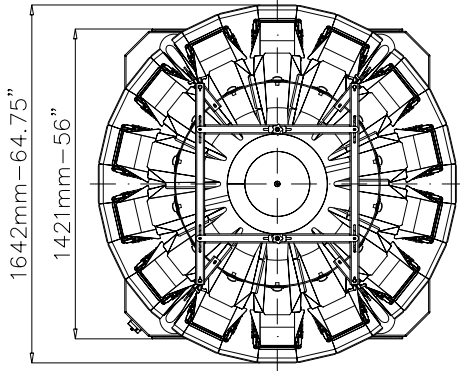

Max. speed	90 wpm
Weigh heads	14
Bucket volume	5,0l
Max. discharge volume (single dump)	12,5l
Discharge weight range (single dump)	100 g - 3000 g
Max. piece length	150 mm
Product distribution	Vibratory or rotary distribution cone with loadcell to control product infeed
Product contact parts	Stainless steel AISI 304 Embossed plate* and special coatings*
Drive	Springless, high speed stepper motors
Loadcells	C3 accuracy class, OIML approved R76 class
Electronic platform	Industrial PC
HMI	12" (18"*) colour touch screen with remote control capability (augmented reality feature*)
Program memory	over 1000 recipes
Power supply (opt. excluded)	230 Vac±5%, 1 ph, neutral, GND, 50/60 Hz, 1.2 kW, 6 A (3 A @ 480 V)
Compressed air (opt. excluded)	180 l/min @ 7 bar
Machine dimensions (W x D x H)	1642 x 1642 x 1727 mm (64.74 x 64.75 x 68")
Machine weight	850 kg

* optional