



STRETCH WRAPPER  
MODEL: CSA 211/212

# CSA 211/212 Advance Smart Technology

Compact, high performance rotating arm machine for wrapping pallets with stretch film. Reliable, robust construction.

## Technical Characteristics

Total power installed	min. 1.2 Kw - max. 2.2 Kw
Standard power supply	230V mono-phase - 50/60Hz - 6A
Protection on electric system & motors	IP 54
Operating pressure (with top pressure)	6 bar
Max pallet dimensions	1000 x 1200 mm
Max pallet height	2500 mm
Production capacity per h	Up to 20

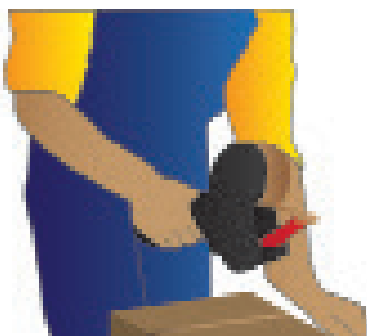

Version 211: Electromagnetic friction adjustable from control panel.

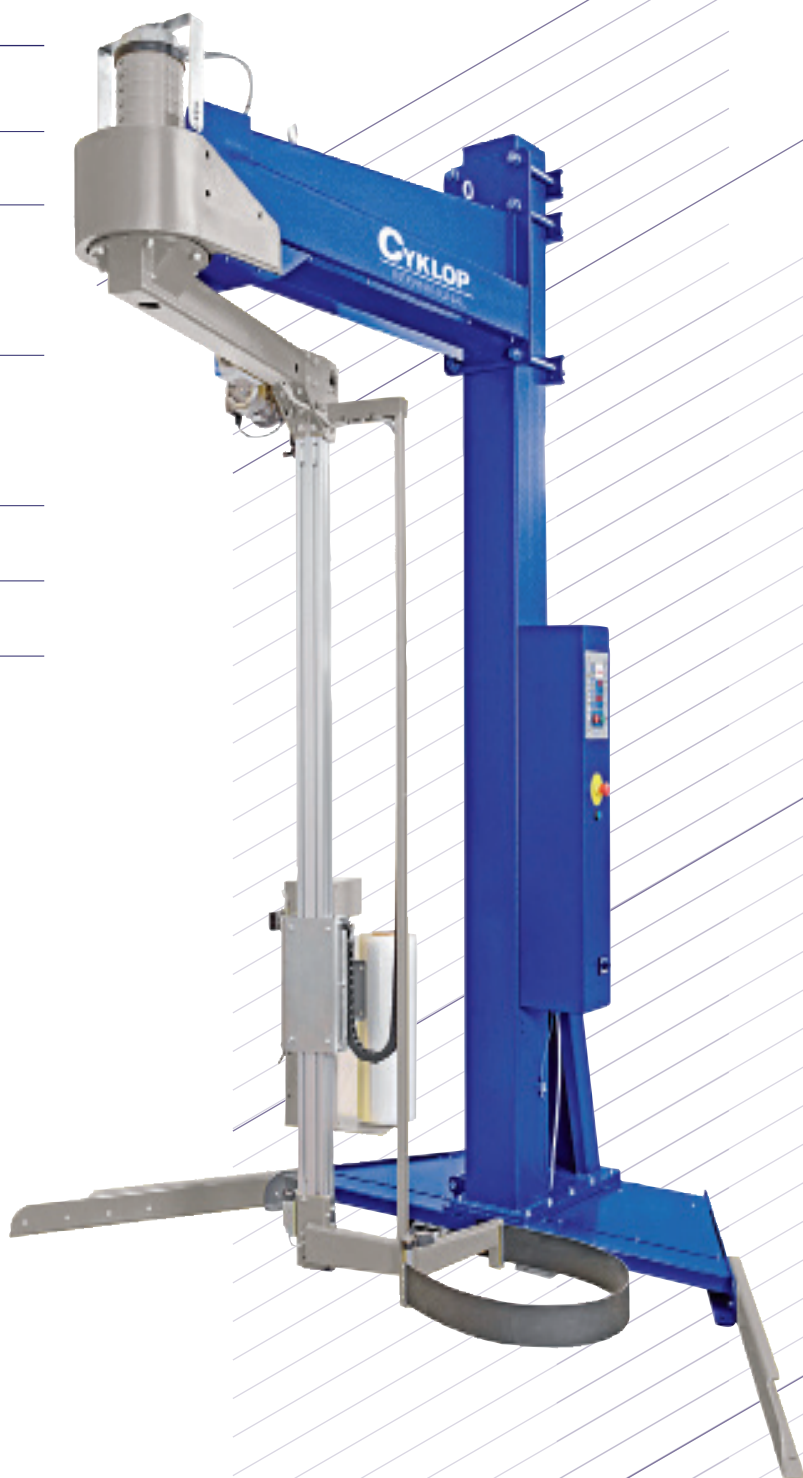

Optionals

- Acid protection.
- Mast for loads up to 3000 mm high.
- Film weight check.
- Pallet holder presser.
- Wall fastening.
- Roping system.

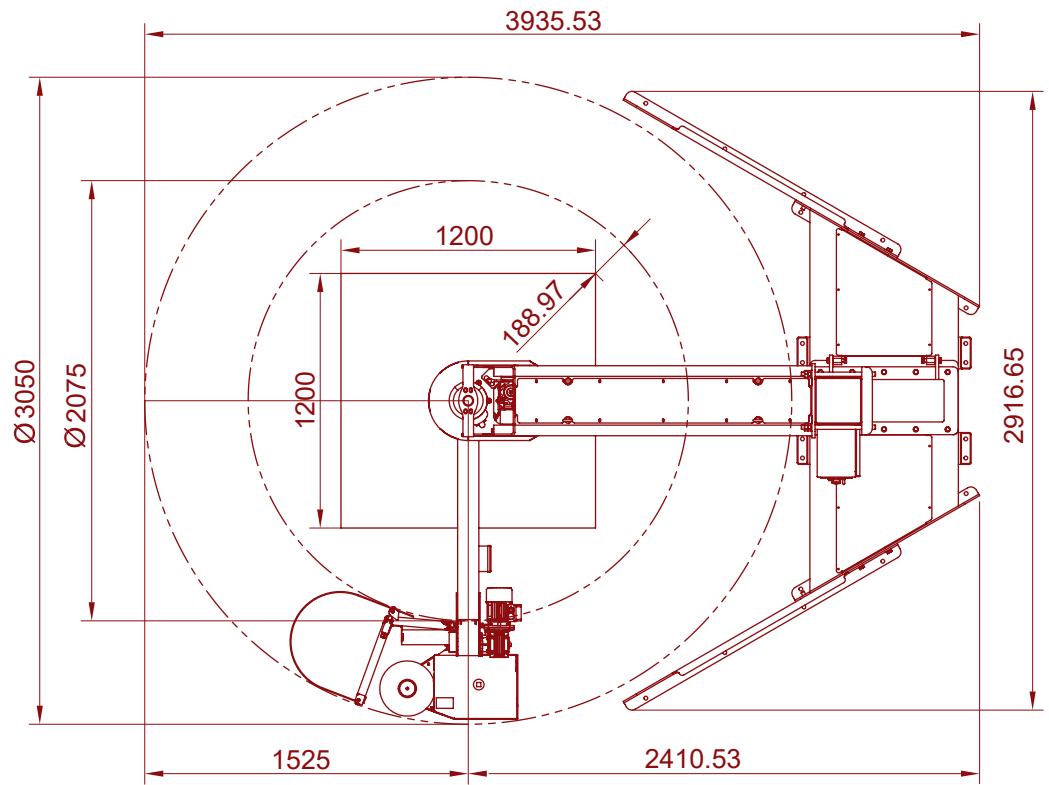

Control panel 99  
programs easy-to-use.

## Save your Money

Version 212: Motorized pre-stretch system with 3 driven rollers electronically controlled with interchangeable ratios: 150 - 200 - 250%.

