



IQ4 Pipeline - Metal Detection System

Designed for the Meat applications

Product Highlights

- Designed on a mobile stand with gas strut for height adjustment, the IQ4 Pipeline is made to inspect meat products such as diced, ground, chopped and slurries, that are vacuum filled under high pressure.
- Robust components designed for easy strip down cleaning at the end of each product run to comply with hygiene standards (EN1672-2)
- Color 7" touchscreen control interface including multi-level password access and data logged events for traceability
- IP69K environmental protection suitable for both high-care and low-care environments
- Fully integrated Performance Validation software



7" Touchscreen with a new easy to use interface

Standard across all of the IQ4 range, the big 7" touchscreen offers 33% more space than previous generation metal detectors and improves usability.

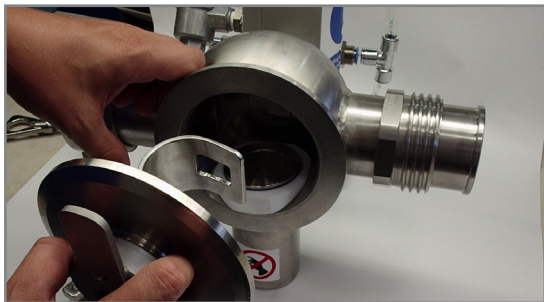

Expertise in Different Product Applications

With over 20 years of research and development in Pipeline applications, our experts know the right reject options for a variety of different products.



Built with filling machines in mind

The IQ4 Pipeline is designed to be compatible with vacuum filling machine brands such as Handtmann, Vemag and Risco.

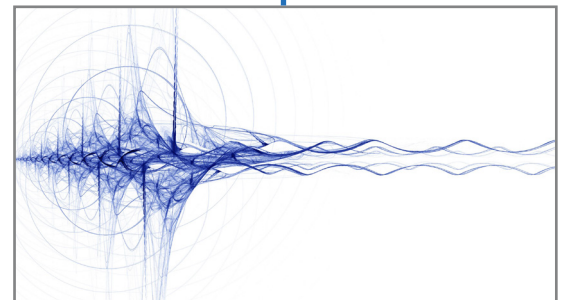

Variable Frequency Provides the Best Detection Levels

The IQ4 Pipeline features LOMA's revolutionary Variable Frequency technology that allows detection levels to be optimized around a wide range of differing product conditions, including whether they are wet or dry.

Technical Specification

Pipe Diameter (")	2.5
Pipe Connections	RD80 - Threaded
Finish	304 stainless steel
Mounting Options	Stand, Hinge (Handtmann)
Supply Voltages	85 to 265 V, single phase 50/60 Hz, neutral & Earth
Power Consumption	20 VA
Air Supply	5 to 8 Bar (10mm Outside Dia) 72-116 PSI
Temperature Range	-10 to +40 °C (14 to 104 °F)
Humidity	0 to 95% Relative Humidity (Non-condensing)
IP Rating	IP69K
PVS Enabled	Yes
Reporting	Batch, Shift
Data Retrieval	Via USB, Ethernet, TRACS
Optional Extras	Remote Control Box

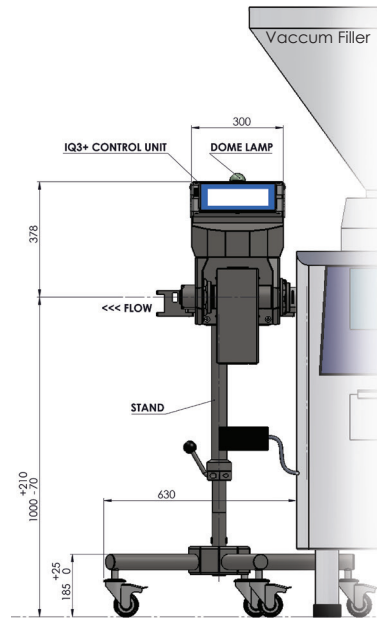

All dimensions in mm, Handtmann VF Filler not Included

Automatic Reject Options

The IQ4 Pipeline can be specified with an automatic reject station with the following options:

	Reject Type	Availabe Sizes (")
Meat	ARI, ARU (Piston) ARL-60 (Rotary)	2.5

